

Entry-level IP phone with 2 Lines & HD voice

Yealink's new SIP-T21(P) E2 takes entry-level IP phones to a level never achieved before. Making full-use of high-quality materials, plus an extra-large 132x64-pixel graphical LCD with backlight showing a clear 5-line data display, it offers a smoother user experience, much more visual information at a glance, plus HD Voice characteristics. Meanwhile, the dual 10/100 Mbps network ports with integrated PoE makes T21P E2 an ideal choice for extended network use. The T21(P) E2 supports two VoIP accounts, simple, flexible and secure installation options, plus support for IPv6, Open VPN and a redundancy server. It also operates with SRTP/ HTTPS/ TLS, 802.1x. As a very cost-effective and powerful IP solution, the T21(P) E2 maximizes productivity in both small and large office environments.



Key Features and Benefits

HD Audio

Yealink HD voice refers to the combination of software and hardware design as well as the implementation of wideband technology to maximize the acoustic performance. Coupled with advanced acoustic clarity technology such as full duplex, echo cancellation, adaptive jitter buffer, etc, the SIP-T21(P) E2 provides clearer, more lifelike voice communications.

Enhanced Call Management

The SIP-T21(P) E2 supports vast productivity- enhancing features such as XML Browser, call park, call pickup, BLF, call forward, call transfer, 3-way conference, which makes it the natural and obvious efficiency tool for today's busy small and large offices environment.

Efficient Installation and Provisioning

The Yealink SIP-T21(P) E2 supports efficient provisioning and effortless mass deployment with Yealink's Redirection and Provisioning Service (RPS) and Boot mechanism to help you realize the Zero Touch Provisioning without any complex manual settings, which makes it simple to deploy, easy to maintain and upgrade.

Highly secure transport and interoperability

The communicator uses SIP over Transport Layer Security (TLS/SSL) to provide service providers with the latest technology for enhanced network security. The range is certified compatible with 3CX and Broadsoft Broadworks, ensuring excellent compatibility with leading soft switch suppliers.

- > Yealink HD Voice
- > 132 x 64-pixel graphical LCD with backlight
- > Two-port 10/100M Ethernet Switch
- > PoE support (T21P E2)
- > Opus codec support
- > Up to 2 SIP accounts
- > Headset support
- > Wall mountable
- > Simple, flexible and secure provisioning options

Audio Features

- > HD voice: HD handset, HD speaker
- > Wideband codec: AMR-WB (optional), Opus, G.722
- > Narrowband codec: G.711(A/μ), G.729AB, G.726, iLBC
- > DTMF: In-band, Out-of-band (RFC 2833) and SIP INFO
- > Full-duplex hands-free speakerphone with AEC
- > VAD, CNG, AEC, PLC, AJB, AGC

Phone Features

- > 2 VoIP accounts
- > Call hold, mute, DND
- > One-touch speed dial, hotline
- > Call forward, call waiting, call transfer
- > Group listening, SMS, emergency call
- > Redial, call return, auto answer
- > Local 3-way conferencing
- > Direct IP call without SIP proxy
- > Ring tone selection/import/delete
- > Set date time manually or automatically
- > Dial plan
- > XML Browser, action URL/URI
- > Integrated screenshots
- > RTCP-XR, VQ-RTCPXR
- > Enhanced DSS Key

Directory

- > Local phonebook up to 1000 entries
- > Black list
- > XML/LDAP remote phonebook
- > Smart dialing
- > Phonebook search/import/export
- > Call history: dialed/received/missed/forwarded

IP-PBX Features

- > Busy Lamp Field (BLF)
- > Bridged Line Appearance (BLA)
- > Anonymous call, anonymous call rejection
- > Hot-desking, voice mail
- > Flexible seating
- > Call park, call pickup
- > Executive and Assistant
- > Centralized call recording
- > Visual voice mail
- > Call recording

Display and Indicator

- > 132 x 64-pixel graphical LCD with backlight
- > LED for call and message waiting indication
- > Dual-color (red or green) illuminated LEDs for line status information
- > Intuitive user interface with icons and soft keys
- > Multilingual user interface
- > Caller ID with name and number
- > Power saving

Feature keys

- > 2 line keys with LED
- > 6 features keys: message, headset, redial, transfer, mute, hands-free speakerphone
- > 6 navigation keys
- > Volume control keys

Interface

- > 2 x RJ45 10/100M Ethernet ports
- > Power over Ethernet (IEEE 802.3af), class 2 (T21P E2)
- > 1 x RJ9 (4P4C) handset port
- > 1 x RJ9 (4P4C) headset port

Other Physical Features

- > Wall mountable
- > External Yealink AC adapter: AC 100~240V input and DC 5V/600mA output
- > Power consumption (PSU): 0.8-1.4W
- > Power consumption (PoE): 1.3-1.8W (T21P E2)
- > Dimension (W*D*H*T): 209 mm*188 mm*150 mm*41 mm
- > Operating humidity: 10~95%
- > Operating temperature: -10~50°C (+14~122°F)

Management

- > Configuration: browser/phone/auto-provision
- > Auto provision via FTP/TFTP/HTTP/HTTPS for mass deploy
- > Auto-provision with PnP
- > Zero-sp-touch, TR-069
- > Phone lock for personal privacy protection
- > Reset to factory, reboot
- > Package tracing export, system log

Network and Security

- > SIP v1 (RFC2543), v2 (RFC3261)
- > Call server redundancy supported
- > NAT traversal: STUN mode
- > Proxy mode and peer-to-peer SIP link mode
- > IP assignment: static/DHCP
- > HTTP/HTTPS web server
- > Time and date synchronization using SNTP
- > UDP/TCP/DNS-SRV (RFC 3263)
- > QoS: 802.1p/Q tagging (VLAN), Layer 3 ToS DSCP
- > SRTP for voice
- > Transport Layer Security (TLS)
- > HTTPS certificate manager
- > AES encryption for configuration file
- > Digest authentication
- > OpenVPN, IEEE802.1X
- > IPv6
- > LLDP/CDP/DHCP VLAN
- > ICE

Package Features

- > Package content:
 - Yealink SIP-T21(P) E2 IP phone
 - Handset with handset cord
 - Ethernet Cable (1.5m CAT5E UTP Cable)
 - Stand
 - Quick Start Guide
 - Power Adapter: T21 E2 (Standard)/T21P E2 (Optional)
- > Qty/CTN: 10 PCS
- > N.W/CTN: 11.7 kg
- > G.W/CTN: 12.5 kg
- > Giftbox size: 215 mm*200 mm*118 mm
- > Carton Meas: 615 mm*436 mm*208 mm

Compliance

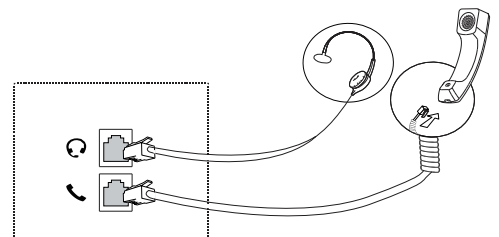
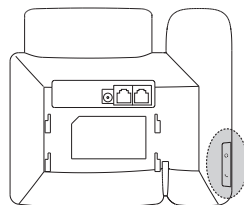
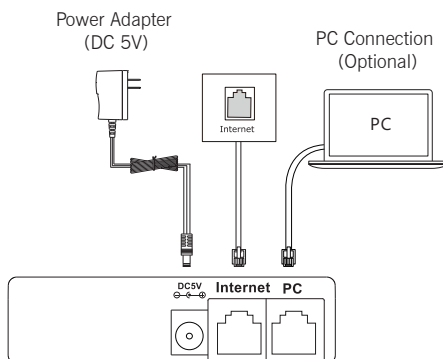

Learn More

To find out how Yealink solutions can help your organization, visit us at www.yealink.com or mail to sales@yealink.com



About Yealink

Yealink (Stock Code: 300628) is a global leading unified communication (UC) terminal solution provider that primarily offers video conferencing systems and voice communication solutions. Founded in 2001, Yealink leverages its independent research and development and innovation to pursue its core mission: "Easy collaboration, high productivity." The company's high-quality UC terminal solutions enhance the work efficiency and competitive advantages of its customers in over 100 countries. Yealink is the world's second-largest SIP phone provider and is number one in the China market.

Copyright

Copyright © 2017 YEALINK(XIAMEN) NETWORK TECHNOLOGY CO., LTD.

Copyright © 2017 Yealink(Xiamen) Network Technology CO., LTD. All rights reserved. No parts of this publication may be reproduced or transmitted in any form or by any means, electronic or mechanical, photocopying, recording, or otherwise, for any purpose, without the express written permission of Yealink(Xiamen) Network Technology CO., LTD.

Technical Support

Visit Yealink WIKI (<http://support.yealink.com/>) for firmware downloads, product documents, FAQ, and more. For better service, we sincerely recommend you to use Yealink Ticketing system (<https://ticket.yealink.com>) to submit all your technical issues.



YEALINK(XIAMEN) NETWORK TECHNOLOGY CO.,LTD.
Web: www.yealink.com
Addr: 309, 3th Floor, No.16, Yun Ding North Road,
Huli District, Xiamen City, Fujian, P.R. China
Copyright©2017Yealink Inc.All right reserved.